



### Sound Enclosures for Vacuum Pump and Vacuum Stations

ANVER Vacuum Tube Lifting Systems use vacuum pumps and vacuum stations that already meet OSHA guidelines for noise levels. For added comfort or for use where low noise is desired as a premium, sound deadening enclosures are available in most common sizes.

As a general rule, sound enclosures reduce sound by 5-7 dB for vacuum pumps operating in the 68-76 dB range. Although this may seem vague, it is true since sound readings can vary by this amount simply by changing the location where you are standing when you are taking the sound readings.

ANVER sound deadening enclosures are built from durable, melt-resistant, industrial-quality plastic. They have a steel plate base and are fully lined with sound deadening foam. It is best to obtain these enclosures when you purchase the

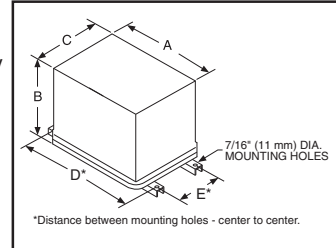

vacuum station as they require special plumbing: the intake and exhaust pipes need to be lengthened to port correctly.

The following enclosure sizes are available from stock. Note that the pricing is for the sound enclosure when sold with the vacuum station. When sold separately, extra pipe fittings, though a small amount, must be added. Check with the factory for details.

ANVER Item No.	A in. (mm)	B in. (mm)	C in. (mm)	D in. (mm)	E in. (mm)
SDE-3	33.00 (838)	24.00 (610)	21.50 (545)	N/A	N/A
SDE-4	33.00 (838)	24.00 (610)	21.50 (545)	35.00 (889)	11.40 (290)
SDE-5	33.00 (838)	24.00 (610)	21.50 (545)	35.00 (889)	12.92 (328)
SDE-6	33.00 (838)	24.00 (610)	21.50 (545)	35.00 (889)	12.92 (328)
SDE-7	33.00 (838)	24.00 (610)	21.50 (545)	35.00 (889)	12.92 (328)
SDE-8	29.25 (743)	30.00 (762)	38.75 (984)	31.25 (794)	19.00 (483)
SDE-9	33.00 (838)	24.00 (610)	21.50 (545)	35.00 (889)	14.64 (372)

### Wall Mount Bracket for Regenerative Vacuum Pumps



ANVER Item No.

ST-W1

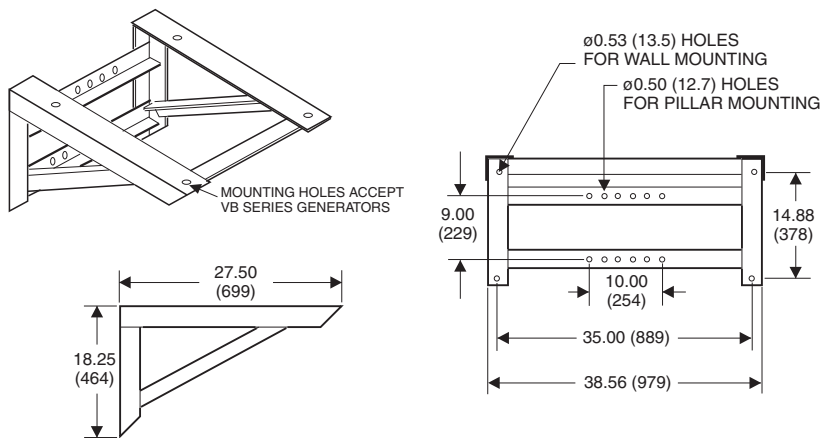

► This spec sheet was adapted for print from our website. Additional information and photos are available at [www.anver.com](http://www.anver.com). 9051801