

Vacuum Pad Attachments



Large Capacity Rectangular Pad Attachments



For Extra Heavy Loads

ANVER Large Capacity Vacuum Pad Attachments are ideal for lifting heavy, compact loads in situations where the available load surface precludes the use of lifters with multiple pads. These larger pads made by ANVER and can be an economical alternative to multiple vacuum pad lifters.

Features:

- Sturdy Steel Construction
- Replacement Bolt-On Vacuum Seal
- High Lifting Capacity

Pad Attachments

ANVER Item No.	Dimensions of Pad Attachment in. (mm)	Weight of Pad Attachment lb. (kg)	Headroom Added to Generator (Bottom of Pad to Mounting Holes) in. (mm)	Maximum Lifting Capacity of Vacuum Pad Attachment Based on Vacuum Generator Used:			
				Capacity with VPF-57HD lb. (kg)	Capacity with M250M lb. (kg)	Capacity with VPE1-H lb. (kg)	Capacity with VPE3-S lb. (kg)
PA2129M-S-36	29.75 x 21.00 (756 x 533)	115 (52)	5 (127)	2800 (1270)	2800 (1270)	2800 (1270)	2800 (1270)
PA1834-S-36	19.13 x 35.13 (486 x 892)	140 (64)	5 (127)	3200 (1451)	3000 (1361)	3200 (1451)	3200 (1451)

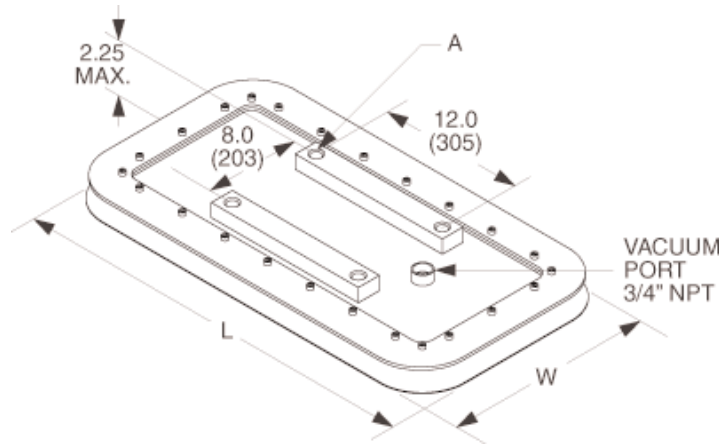

Single Pads

Product Number	Replacement Seal Number	W in. (mm)	L in. (mm)	A Mounting Holes	Weight lb. (kg)	Rated Load* lb. (kg)
VP2129Q	2129M	21.00 (533)	29.75 (756)	3/4-10 UNC	-	2800 (1270)
VP1834Q	SR-1834-DP	19.13 (486)	35.13 (892)	3/4-10 UNC	130 (59)	3200 (1451)
76200887	SR-1834-DP	19.13 (486)	35.13 (892)	1-8 UNC	130 (59)	3200 (1451)

► This spec sheet was adapted for print from our website. Additional information and photos are available at www.anver.com. 0120801

36 Parmenter Road • Hudson MA 01749 USA • 978-568-0221 • 800-654-3500 • FAX 978-568-1570 • www.anver.com • E-Mail: sales@anver.com