

Vacuum Pumps and Generators

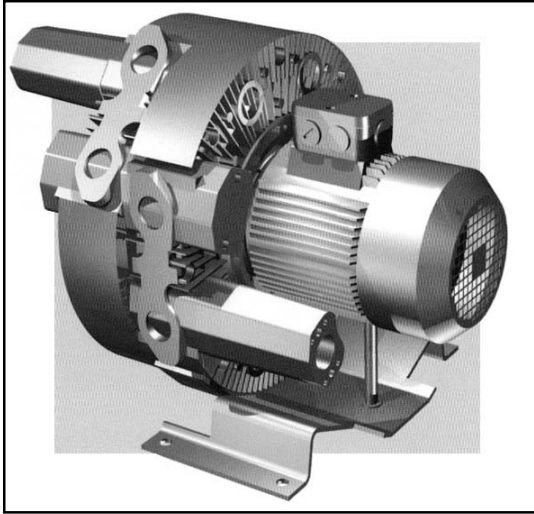

High Vacuum RB Series Regenerative Pump RB-061-12



Features:

- Oil free
- Maintenance free
- Operates quietly - maximum 70 dB (A)
- Cooler running outboard bearings increase service life
- Easy to install, close-coupled construction
- Compact lightweight design
- Ideal alternative to standard rotary vane pumps and PD/rotary lobe blowers

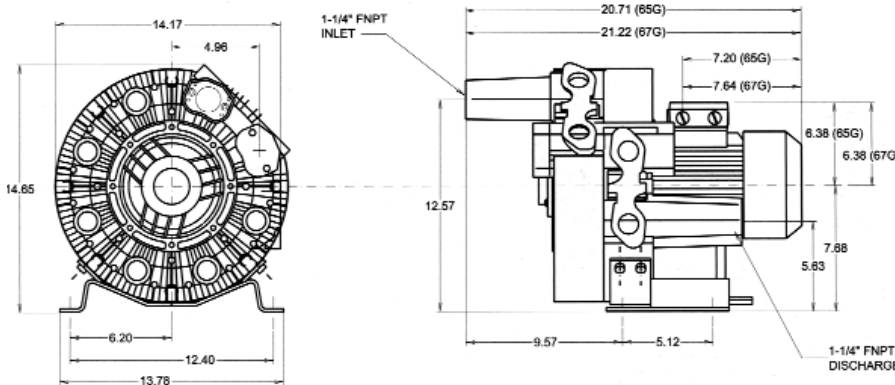

Performance Curves: 60Hz Vacuum

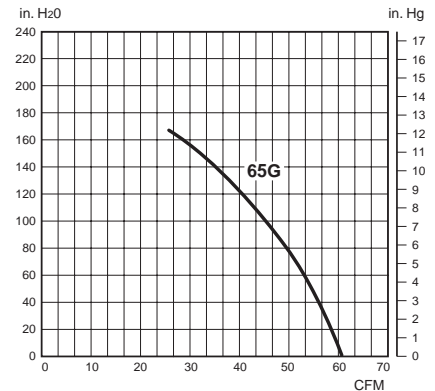

Curve No.	Motor Type	Motor HP (Kw)	Voltage	Phase-Frequency	Rated Motor Amps	Shipping Weight lb (kg)	Sound Level
65G	TEFC	2.40	208-230/415-460	3-60Hz	7.0/3.5	73 (33.1)	66 dB(A)

NOTES:

- Standard voltage for three phase blowers is 208-230/415-460V 3ph/ 60Hz.
- Standard voltage for single phase blowers is 115/230/1ph/50/60Hz or 115V/1ph/60Hz or 230V/1ph/60Hz.
- All blowers available in 50Hz frequency and with other voltages.
- All blowers operate at 3600 RPM.

Specifications subject to change without notice. • Please contact factory for specification updates.

► This spec sheet was adapted for print from our website. Additional information and photos are available at www.anver.com. 9022301

36 Parmenter Road • Hudson MA 01749 USA • 978-568-0221 • 800-654-3500 • FAX 978-568-1570 • www.anver.com • E-Mail: sales@anver.com