

Vacuum Pumps and Generators

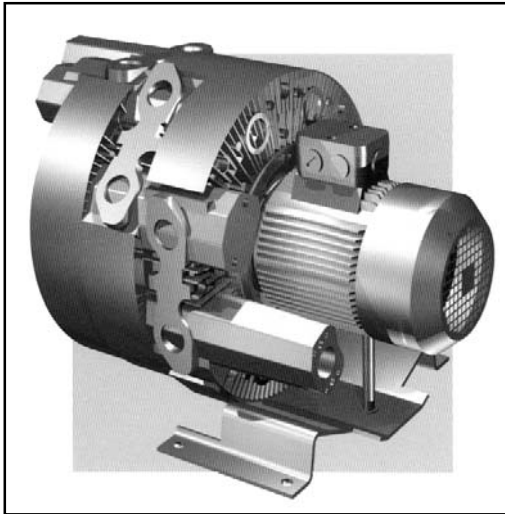

High Vacuum RB Series Regenerative Pump RB-120-20



Features:

- Oil free
- Maintenance free
- Operates quietly - maximum 70 dB (A)
- Cooler running outboard bearings increase service life
- Easy to install, close-coupled construction
- Compact lightweight design
- Ideal alternative to standard rotary vane pumps and PD/rotary lobe blowers

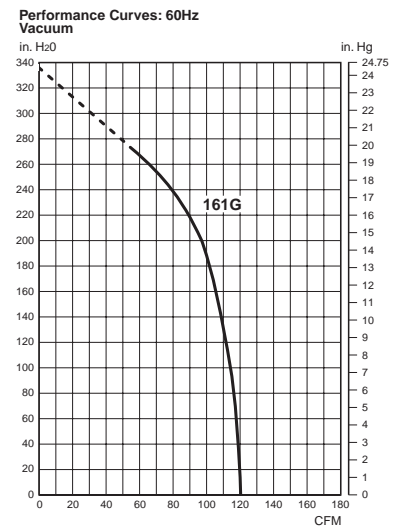
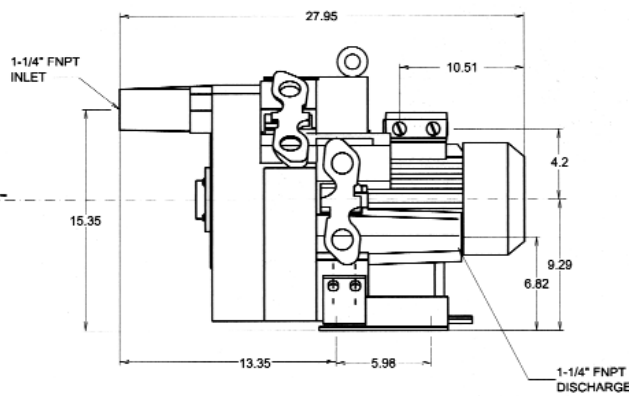
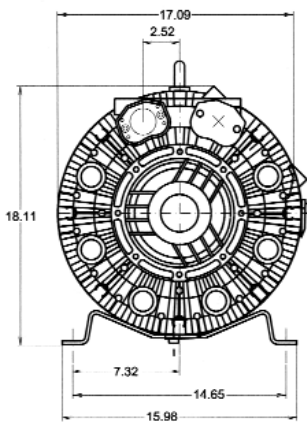

Curve No.	Motor Type	Motor HP (Kw)	Voltage	Phase-Frequency	Rated Motor Amps	Shipping Weight lb (kg)	Sound Level
161G	TEFC	7.5	208-230/415-460	3-60Hz	20/10	104 (47.2)	72 dB(A)

NOTES:

- Standard voltage for three phase blowers is 208-230/415-460V 3ph/ 60Hz.
- Standard voltage for single phase blowers is 115/230/1ph/50/60Hz or 115V/1ph/60Hz or 230V/1ph/60Hz.
- All blowers available in 50Hz frequency and with other voltages.
- All blowers operate at 3600 RPM.

Specifications subject to change without notice. • Please contact factory for specification updates.

► This spec sheet was adapted for print from our website. Additional information and photos are available at www.anver.com. 9042301