

Vacuum Cups & Suction Cups



Large Hinged Oval Vacuum Cups



ANVER's OCP Series Oval Vacuum Cups have been specifically designed for lifting pipe and other cylindrical loads. These cups are hinged down the center in order to conform to varying diameters, making them a practical and economical lifting solution for a variety of situations.

The OCP Series Vacuum Cups should be used in conjunction with a clevis mounting configuration, in order to maximize the cup's versatility. OCP Series Oval Vacuum Cups are available in three sizes with a steel mounting hub.

Note: The current design looks slightly different to the above photo as it incorporates a number of design improvements.

ANVER Item No.	A in. (mm)	B in. (mm)	H1 in. (mm)	H2 in. (mm)	Rated Capacity lb (kg)	Minimum Pipe Diameter In. (mm)
OCP45-118NBR	11.8 (300)	4.5 (115)	0.71 (18)	1.34 (34)	150 (68)	9 (229)
OCP71-197NBR	19.7 (500)	7.1 (180)	0.75 (19)	16.1 (41)	450 (204)	14 (356)
OCP79-295NBR	29.5 (750)	7.9 (200)	0.98 (25)	2.13 (54)	750 (340)	16 (407)

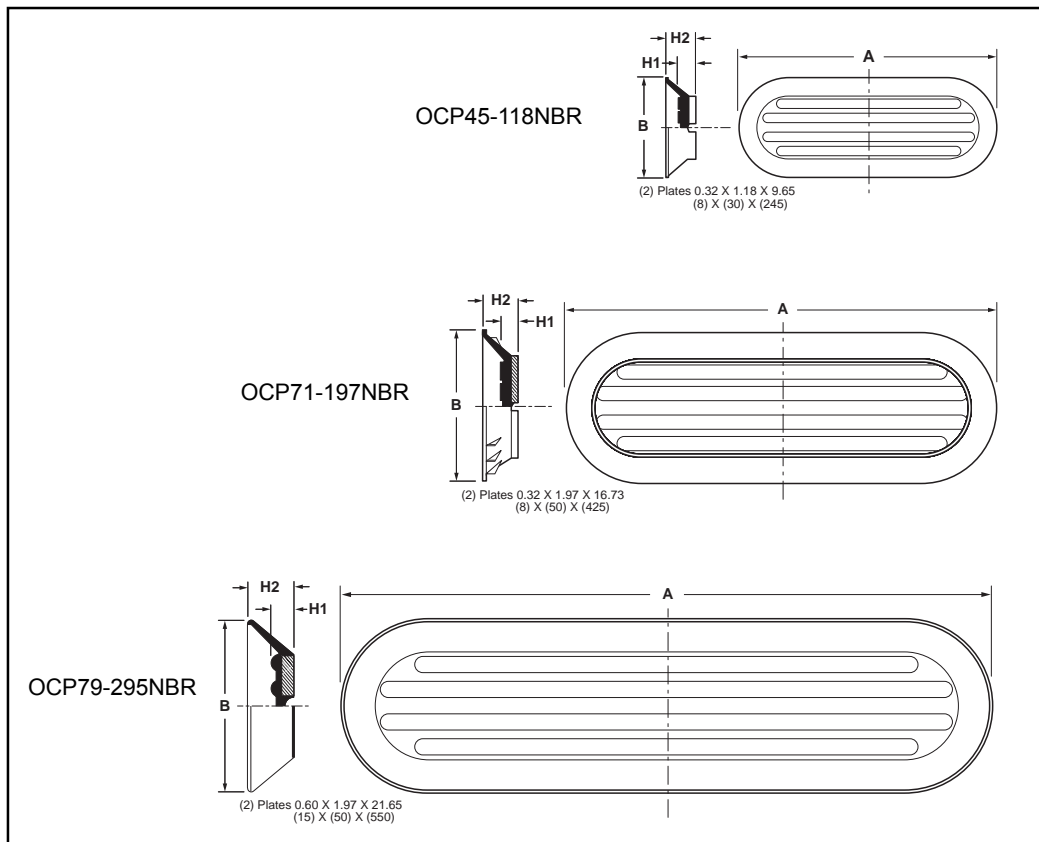

► This spec sheet was adapted for print from our website. Additional information and photos are available at www.anver.com. 6081301